

PACKO TWIN-SCREW PUMPS

**VERDER**  
passion for pumps



**PACKO ZS SERIES**

Hygienic twin-screw pumps

Operation & maintenance manual

**Packo**  
A VERDER COMPANY

# CONTENTS

---

## GENERAL

General Information .....	1
Manufacturer.....	1
Copyright.....	1
Declaration of conformity.....	2
Intended Use .....	3
Type designation.....	3
Sound pressure level.....	4
Construction .....	5
Packaging & Transport .....	6
Storage .....	6

## SAFETY

DO'S and DON'TS .....	7
ATEX safety measures.....	8

## INSTALLATION

Installation .....	9
Connection of the motor.....	9
Start Up .....	11

## OPERATION

Troubleshooting .....	12
Cleaning .....	13

## MAINTENANCE

Screw Case Disassembly .....	14
Screw Case Assembly .....	16
Screw Rotor Clearance .....	18
Gearbox Maintenance .....	19
Integration Type Unit Assembly .....	22
Lubrication .....	23

## TECHNICAL INFORMATION

Technical Data .....	24
----------------------	----

## EXPLODED VIEWS

Exploded View.....	25
--------------------	----

# GENERAL

---

## GENERAL INFORMATION

Thank you for purchasing PACKO pumps!

This manual for the ZS series Twin Screw Pumps describes safe and appropriate operation during operating and in all life cycles.

This manual contains instructions for installation, operation, disassembly and assembly, maintenance procedures and troubleshooting.

Read and completely understand this manual prior to operating or servicing the product and observe to pay special attention to the warnings.

This manual must always be available at the installation location since no liability will be assumed for any damage or operational malfunctions arising from non-compliance with these operating instructions.

## MANUFACTURER

PACKO INOX LTD  
Cardijnlaan 10  
B-8600 Diksmuide  
Belgium  
Telephone: + 32 51 51 92 80  
Telefax: + 32 51 51 92 99  
E-mail: [pumps@packo.com](mailto:pumps@packo.com)

## COPYRIGHT

These operating instructions are written to support the installation, the use and the maintenance of the pump in accordance with the European machinery directive. They are originally written in Dutch, English, French and German by the manufacturer. All other languages are translations of the original operating instructions.

PACKO INOX LTD has the copyright on this document. These operating instructions may be reproduced in full in the operating instructions of the machine or installation in which the pump is installed and may be used for training personnel who must work on or with the pump. Any other publication, reproduction in full or parts thereof is prohibited.

Although these operating instructions have been carefully drawn up, they do not however cover all possible eventualities that can occur during the installation, operation or the maintenance of the pump. In any event, the pump must not be used for purposes other than those stated when ordering and for which the pump has been constructed, as this could result in physical damage and injuries.

## **DECLARATION OF CONFORMITY**

Manufacturers' declaration according to annex IIA of the  
"Machinery" Directive 2006/42 EC

We,

Packo Inox Ltd  
Cardijnlaan 10  
B-8600 DIKSMUIDE  
BELGIUM

confirm that the Packo pump type ....., with serial number .....  
fully complies with the Directive Machinery and with the (harmonised) standard EN 809,  
ENISO12100.

It must be brought to your attention that our product is intended to be built into a machine,  
and that, on the basis of the "Machinery" Directive, the complete (compound) machine can only  
be applied after matching the stipulations of the European demands.

PACKO Inox Ltd, Cardijnlaan 10, B-8600 DIKSMUIDE, BELGIUM is authorized to make up the  
technical construction file.

Date

.....

Signature:

.....

Wim Bonte  
BU Manager pumps  
Packo Inox Ltd

## INTENDED USE

The pump should only be used for pumping the media it was selected for during the selling process and within the limits specified in the technical datasheets. Any other application beyond the intended use or conversion of the pump without written agreement with the manufacturer shall be deemed to be not in accordance with the intended use.

The pump may only be started up for the first time if it has been ensured that all safety devices are completely fitted and functional.

If any areas are subject to have the risk of explosion, the relevant explosion-proof designed pumps should be used.

Intended use also covers compliance with the conditions of operation, servicing and maintenance specified by the manufacturer.

The pump is only to be put into operation filled with medium to be pumped.

Before starting up ensure that;

- Open the valves on the suction side completely to avoid cavitation and,
- Open the valves on the discharge side completely to avoid exceeding the permitted differential pressure of the pump
- Discharge-side safety measures should be done (e.g. safety valve) to protect the pump from non-permitted excess pressure
- Protection against contact for hot, cold and moving parts must not be removed during operation

## TYPE DESIGNATION

The type designation can be found on the pump name plate and also on both the order confirmation and customer invoice.

PACKO INOX LTD DIKSMUIDE BELGIUM		<b>Packo</b>	
TYPE:			
Mat. code:			
Year:	S/N:		kg
Max:	bar		°C
DO NOT RUN PUMP DRY OR AGAINST CLOSED VALVE			

Example (an X in the code denotes a special version):

Type: ZS/120-213/114

- ZS: pump series
- 120: pump type
- 213: speed of the pump when the motor operates at 50Hz
- 11: motor power in kW multiplied by ten (11 = 1.1 kW)
- 4: number of poles of the motor

Mat. Code: (TS-120) D37SSVQ

- TS: Rotor type (TS = twin screw)
- 120: temperature class of the pump (Deg. C)
- D: type of couplings (D = DIN 11851, B = BSP, E = DIN 2642, F = DIN 2576, R = RJT, S = SMS, I = IDF, T = Tri-Clamp ISO2852, M = Tri-clamp ASME BPE, O = Tri-clamp ISO, N = ANSI flanges, V = DIN 11864-1, A = DIN 11864-2)
- 37: housing size of the NORD reductor
- S: seal configuration (S = standard single seal, Q = quench, D = double seal)
- S: mechanical shaft seal materials (S = silicon carbide / silicon carbide, T = tungsten carbide / tungsten carbide)
- V: elastomer materials (E = EPDM, V = viton, M = teflon, K = perfluor elastomer)
- Q: options (T = pump and motor reductor on trolley, U = pump and motor reductor on trolley with cover, P = pump with bare shaft, Q = pump and motor reductor aligned on base plate, R = pump and motor reductor aligned on base plate with cover)

Moreover, the year and week of construction, the pump serial number (to be stated when ordering spare parts), the weight and the operating point for which the pump has been selected, are also marked on the name plate.

## **SOUND PRESSURE LEVEL**

The sound-pressure level of the pump, operating at 50Hz without cavitation measured at 1m is less than 70dB(A). In order to minimize noise and vibration, no other parts of the machine may vibrate with the pump. The best solution is therefore to allow the pump to rest directly on the concrete floor, or to fit shock absorbers between the pump and the frame of the machine.

## CONSTRUCTION

ZS series can be ordered with bare shaft, i.e. pumps without motor or common bed.



Example Layout of pumps:

- ① Screw case with outlet (typically),
- ② Front cover with Inlet (typically),
- ③ Gearbox

Or, ordered as a 'complete unit with B3 type drive motor, coupling & guard, common bed' and layout described as below.

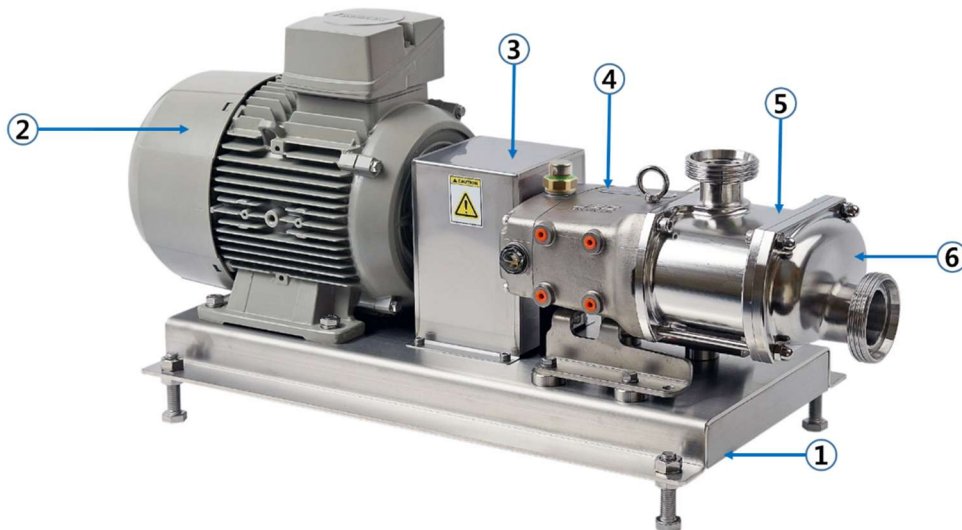

Example Layout of pumps with complete unit

- ① Common bed,
- ② Drive unit,
- ③ Coupling & coupling guard,
- ④ Gearbox,
- ⑤ Screw case with outlet (typically),
- ⑥ Front cover with Inlet (typically)

## PACKAGING & TRANSPORT

ZS series are shipped in non-returnable wooden packaging. Unpack the pump/unit upon delivery and inspect it for visible transport damage. Any damage occurred during the transporting has to be immediately reported to the transport agent after receipt of the consignment. Do not put the damaged products into operation.

The pumps need to be transported and secured with care to ensure no damage is caused. Lifting equipment (hoist) and load securing straps must be placed with sufficient load capacity. Make sure you set the pump down on a stable, horizontal surface.

Below picture of complete unit with drive & common bed is shown as an example.

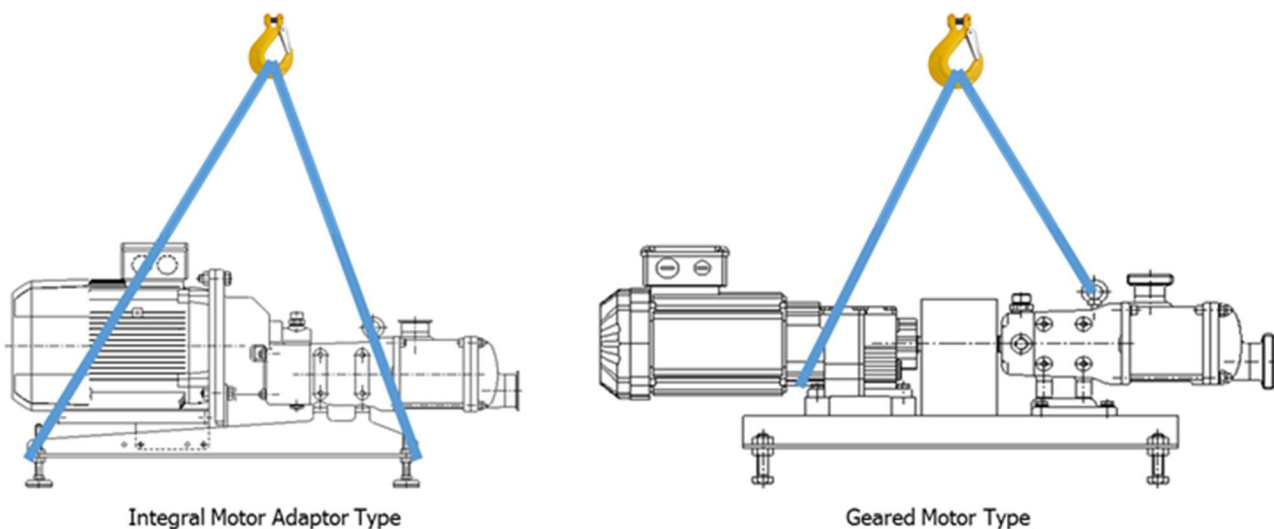

**Caution** \*Do keep alignment between pump's and motor's shafts.  
\*Do not lift the pump by the screw case, gearbox or integral adaptor.

## STORAGE

If the pumps need to be stored temporarily, they should be sufficiently preserved under normal environmental conditions and must not be exposed to the weather for any significant period of time.

Heed below measures when a longer storage period is required.

1. Protect pumps against dust, dirt, water or any other harmful environmental factors. Coat all non-painted surfaces with acid-free and resin-free grease.
2. Do not grease stainless steel parts and non-metallic parts.
3. Close all openings of pressure and suction ports.
4. Drain water when using it as flushing/quench medium for the shaft seal.



# SAFETY

---

## DO'S & DON'TS

- DO** read and understand these instructions before installing or using the pump.
- DO** use PACKO spare parts when replacing a component of the pump.
- DO NOT** service the pump while it is running.
- DO NOT** place the pump in an application where the service ratings are exceeded.
- DO NOT** modify the pump. Modifying the pump creates unsafe conditions and voids all warranties.

## SAFETY PRECAUTIONS WHEN INSTALLING THE PUMP

- DO** use an authorized electrician when connecting the pump.
- DO** observe the mechanical limits of the pump (refer to the pump performance sheet).
- DO** earth the base plate of the pump to avoid the potential buildup of static electricity.
- DO NOT** install a throttling valve in the suction line.

## SAFETY PRECAUTIONS WHEN OPERATING THE PUMP

- DO:** only qualified personnel should operate this pump.
- DO NOT** start the pump until all personnel are clear.
- DO NOT** touch the pump or the lines when pumping hot fluids or when performing Clean In Place (CIP) procedures.
- DO NOT** run the pump with BOTH the suction inlet and discharge outlet blocked. Running the pump with the inlet or outlet blocked will cause serious damage to the pump.
- DO NOT** check the pump rotation with liquid in the pump.
- DO NOT** run the pump with the front cover removed. The rotors and rotor case could be damaged or may cause severe injury.
- DO NOT** operate the pump with removed safety guard or shroud.

## SAFETY PRECAUTIONS WHEN SERVICING THE PUMP

- DO** ensure the pump is cool to touch before performing service.
- DO** relieve all pressure and drain all fluids from pump and connected piping before performing service.
- DO ENSURE POWER TO THE UNIT HAS BEEN UNPLUGGED PRIOR TO PERFORMING ANY PUMP MAINTENANCE OR CLEANING.**
- DO** exercise caution and wear protective clothing when using lye or acid for cleaning.

## ATEX SAFETY MEASURES

Pump type	Risk		<b>Dry running of mechanical seal</b> (overheated seal faces are an ignition source)	<b>Leakage</b> (inflammable liquid can come into the atmosphere)
	Liquid			
<b>Flooded suction Pump</b>	Non ignitable liquid		<ul style="list-style-type: none"> <li>• Flushed mechanical seal</li> <li>• or flow monitoring to be installed by the customer</li> </ul>	No danger
	Ignitable liquid			<ul style="list-style-type: none"> <li>• Flushed mechanical seal</li> <li>• or single seal with preventive maintenance by the customer</li> </ul>

The flashpoint of a combustible liquid is the lowest temperature at which sufficient vapor is created above a combustible liquid so that it can ignite when mixed with air. However, be aware that the temperature of certain spots on the pump (e.g. the mechanical seal or motor) could be warmer than the temperature of the circulated liquid. Therefore, if the flashpoint of the liquid is above the temperature it is pumped but below 135°C, it should also be considered as ignitable when considering the risk leakage.

Please be aware that if a mechanical seal runs dry, the temperature of the seal faces can rise above 400°C.

### **Pumps with flushed mechanical seal:**

You have to make sure there is a continuous circulation of the flushing liquid and the motor is stopped immediately in case of lack of flushing liquid. Otherwise the mechanical seal can run dry and generate dangerous high temperatures. When a quench reservoir is applied, the level of the flushing liquid in the quench reservoir must be guarded by an ATEX approved level sensor. If the level becomes too high or too low, the pump must be stopped. The temperature in the quench reservoir should be guarded by an ATEX approved temperature sensor. The temperature of the flushing liquid should be kept below 75°C. If necessary an external cooling system should be used to keep the flushing temperature under 75°C. It is the responsibility of the end user to use a suitable flushing liquid for the mechanical seals. The mix of the flushing liquid and the pumped liquid must not create any dangerous or explosive gasses.

The pump should never run with closed valve.

### **Pumps with single mechanical seal:**

You must monitor the flow (e.g. with an ATEX approved flow sensor on the inlet of the pump). If there is no flow detected, you must stop the motor immediately.

Leakage of an ignitable liquid is a serious safety risk. The end-user has to evaluate the consequences of the leak and adjust the check frequency for leak of the mechanical seal. In case leak is detected, the pump must be stopped and the mechanical seal has to be replaced. The mechanical seal has to be replaced preventively every 3000 operating hours.

**The baseplate of the pump must be earthed in order to prevent a build-up of static electricity.**

**The pump must not pump liquids warmer than 108°C.**

The pump should not be started before compliance with all these safety measures.

# INSTALLATION

## INSTALLATION

1. Mounting surface should be flat and level.
2. Ensure at least 0.5m clearance around the pump.
3. Normally, pump and drive unit are configured with common bed. If you want another configuration, feel free to contact PACKO.
4. To check the direction of the rotor's rotation, start and stop the motor for a short time.
5. Before connecting pipelines, check the location of suction and discharge.
6. Ensure the pipelines are connecting correctly and tightly.
7. The suction line should be kept as short as possible and present minimum friction loss.
8. To check the working condition correctly, we recommend installing a pressure relieve valve and pressure gauge at discharge line.
9. Suction and discharge lines must be fully supported and installed so that no expansion or shock forces act on the pump which could lead to distortion.
10. Ensure sufficient clearance around the motor and pump.
11. The coupling alignment must be checked and readjusted if necessary.

## CONNECTION OF THE MOTOR

The electrical connections may only be made when no electrical power is connected and by qualified personnel in accordance with EN 60204 and the local regulations. Special attention must be paid to optimal earthing of the motor; this must be performed in accordance with the applicable regulations in the relevant country. Check on the name plate of the motor whether the motor can operate from the available voltage and frequency.

The connecting cables and the protection system against excessive currents must be chosen according to the data on the name plate of the motor. The voltage drop during the starting of the motor may not exceed 3 %.

Tighten the nuts of the connector terminals in accordance with the torque values (Nm) stated below:

Terminal	M4	M5	M6	M8	M10	M12	M16
Steel	2	3.2	5	10	20	35	65
Copper	1	2	3	6	12	20	50

Do not install any washers or nuts between the cable lugs of the motor windings and the cable lugs of the connecting cables.

Inspect the seal of the gland. The gland must match the diameter of the connecting cable used. Bending of the cable beside the gland must not allow water to penetrate. (Allow the cable to be routed downwards when it leaves the motor.)

Connect the motor in star or delta according to the designation on the name plate of the motor and in accordance with the diagram that is installed in the terminal box. Do not connect the motor if you have any doubts regarding the interpretation of the connection diagram. If in doubt please contact PACKO. Never check the direction of rotation of the pump when the terminal box is open. The

technician is responsible for complying with the regulations relating to electrical compatibility in the country where the pump is installed.

The voltage and the frequency stated on the name plate of the motor must be observed.  
(Tolerance of 5 % for the voltage, and 1 % for the frequency.)

For pumps whose power exceeds 7.5 kW, special starting provisions must be provided (star-delta starter, soft starter, or starting with frequency converter).

The motors are equipped with a thermal relay tripping contact. This contact opens when the motor is in danger of becoming too hot. The connector terminals of the thermal relay tripping contact are located in the terminal box of the motor and are marked as T1 and T2.

**The installation of a high-current protection device is always mandatory.**

## **DIRECTION OF ROTATION**

The direction of rotation of the pump determines the flow direction through the pump as shown in the pictures below.

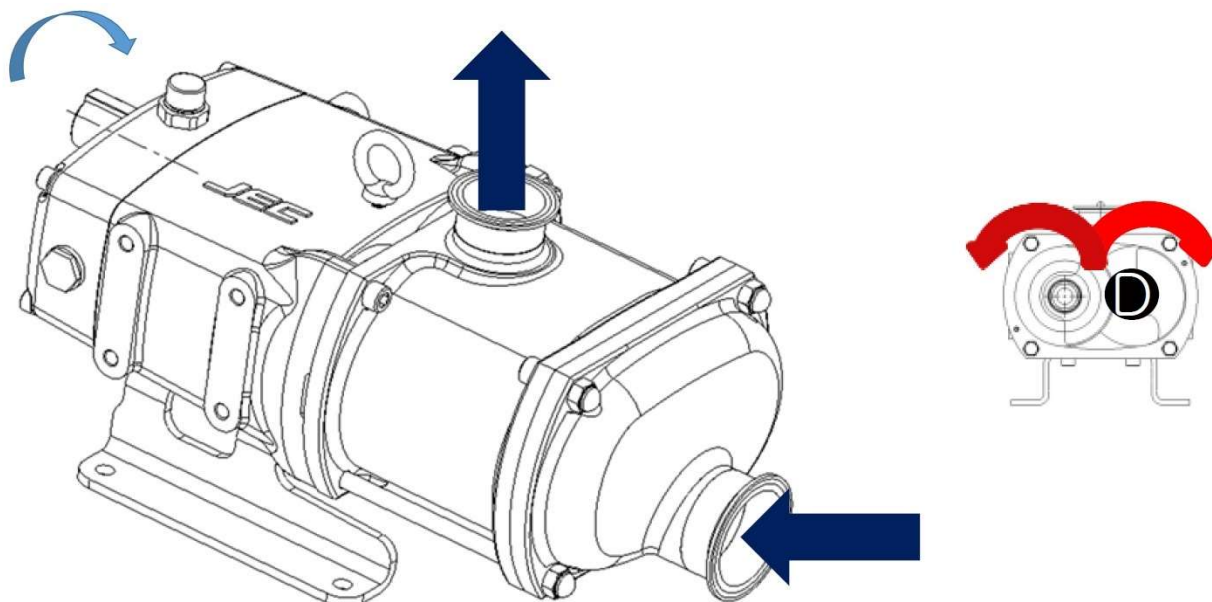

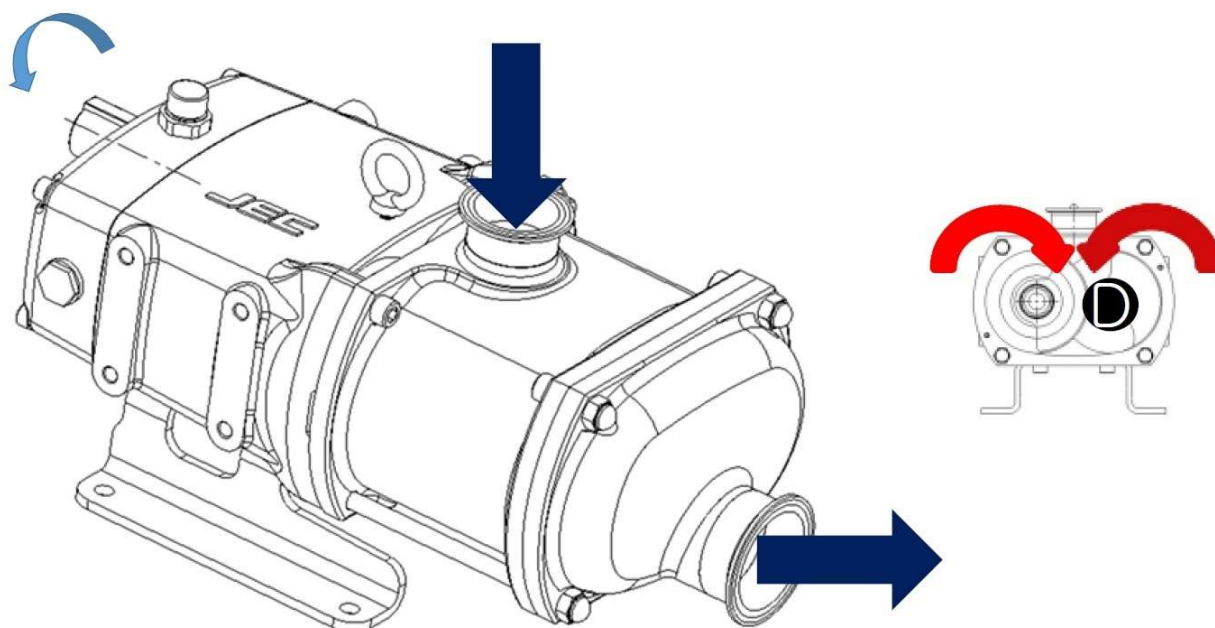

## START UP

1. Before connecting the suction and discharge pipe work the entire system must be thoroughly cleaned to prevent damage from welding, grinding and other residues.
2. Before starting, bump the motor to check if the motor fan is rotating clockwise or counterclockwise when seen from the motor back. If the motor fan cannot be seen, look through the pump case adaptor after removing the motor shroud. (Bump means to momentarily apply power to the motor and then immediately remove power).
3. Where double mechanical shaft seals are installed the flush supply must be operational. Any dry running will result in seal damage.
4. The motor rating plate should be checked to ensure that it is in accordance with the available electrical supply. It is essential that the full load current is not exceeded to prevent motor overload.
5. Before start up any safety guards required by local statutory regulations should be fitted.
6. The pump must never be driven against a closed discharge valve. Please make sure the pressure at the discharge does not exceed the maximum pressure as indicated in the technical information further in this manual. The installation of a pressure relieve valve is recommended.

### **Pay attention to circumstances that could indicate pump cavitation;**

1. Low pressure in the suction line due to bad suction conditions.
2. Air in the suction inlet line.
3. Pumping temperature is too high.
4. Pump is oversized.

# OPERATION

## TROUBLESHOOTING

Problem	Cause	Solution
Pump not turning	<p>Interruption of electrical power. Key sheared or missing. Coupler or belts are not connected. Pump shaft or gears sheared. Wrong rotation. Relief valve not properly adjusted.</p>	<p>Reset circuit breaker, check fuses. Replace. Replace or adjust. Replace. Reverse. Adjust valve.</p>
Pump not priming	<p>Valve closed in suction lines. Suction line clogged or restricted. Air leak in connections or seal. Pump speed too slow. Suction line does not remain flooded. Air lock. Excessive clearances in pump. Net inlet pressure low. Wrong rotation</p>	<p>Open valve. Clear suction line. Repair leak. Increase speed. Install foot valve. Bleed suction line. Replace out of tolerance parts Increase suction pressure Reverse</p>
Insufficient flow	<p>Speed too low. Air leak.</p>	<p>Adjust speed as required. Repair leak.</p>
Noisy operation	<p>Cavitation. Viscous product. High vapor pressure, high temp. Leaks in piping or pump. Dissolved gas in product. Mechanical noise. Excessive weight from piping. Pump body distorted. Excessive discharge pressure. Worn bearing. Worn gears. Rotor-to-rotor contact.</p>	<p>Increase net inlet pressure. Slow pump, reduce product. Reduce temperature. Repair leaks. Reduce discharge pressure. Check tolerances. Support piping. Check align and level Reduce discharge pressure. Replace bearing. Replace gears Time rotors, replace twisted shafts, replace worn gears.</p>
Pump overloads	<p>Viscosity of product higher than expected. Higher pressure than expected.</p>	<p>Reduce pump speed, increase piping size, Reduce pump speed, increase pipe size,</p>
Play between gears	<p>Worn gear teeth. Gear loose on shaft.</p>	<p>Replace gear. Inspect gear key, keyway and shaft. If all are undamaged, retighten the gear retaining nut. Check for backlash.</p>

If assistance is required, please contact your local sales office with the following information:

1. Operating conditions.
2. Accurate description of default.
3. Model of pump and serial number.
4. If possible installations sketch of the pump system.



## CLEANING

1. Before cleaning the pump, wear rubber gloves and protective glasses.
2. While CIP and SIP process, do not touch the pump and pipelines.
3. Ensure velocity rate of CIP solutions is adequate to clean entire circuit. For most applications a velocity of 1.52 m/sec is sufficient. For the CIP solution to achieve the proper velocity, the pump drive must have enough speed range and power. The required inlet pressure also must be satisfied. If the pump does not supply enough CIP solution velocity, a separate CIP supply pump with an installed bypass may be used.
4. Refer to the below CIP and SIP process.

### General C.I.P (Clean In Place) Process

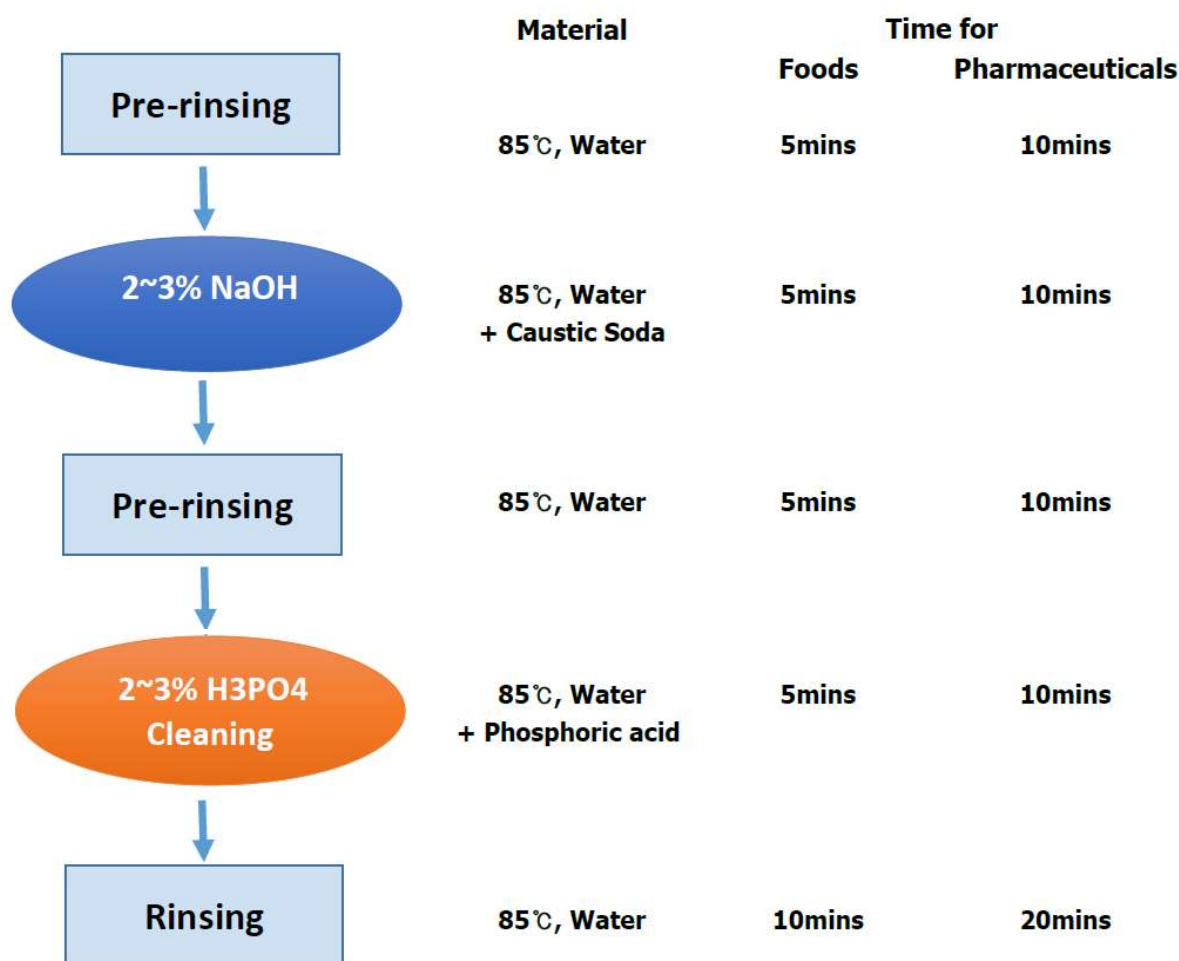

\* The working time is minimum time, the working time can be longer than indicated time, depends on the working conditions.

### General S.I.P (Sterilization In Place) Process

1. Stop the pump's operation.
2. After cleaning the pump, sterilize it by using the steam as 115~120°C for 20-30 minutes.

\* The working time is minimum time, the working time can be longer than indicated time, depends on the working conditions.

## MAINTENANCE

### SCREW CASE DISASSEMBLY

Prior to removal of the pump, the shut-off valves in the suction and discharge pipe work must be closed. If there is any risk that the product may be hardened, crystallized or frozen in the pump it should be thoroughly drained and cleaned immediately after use. Similar attention must be applied to the seal flushing system. Remove the power before servicing to prevent any unintended start of the pump by an authorized electrician.

Remove the Front cover after removing the four cap nuts from the cover. If it is stuck, tap on the front cover with a soft mallet.



Extract screw bolts and spring washers.



Pull out the twin screws from the shafts and treat carefully the screws to avoid damage. If they are stuck, they can be pulled out by extraction tool.



Pull out both the seal rings for stationary parts.





Release the wrench bolts that hold the screw case on the gearbox.



If it is stuck tight, tap alternately on the rim of the screw case with a soft hammer.



Carefully slide the pump casing along the stud bolts and pull the pump casing off the gearbox.



***If you want to replace the seal ring only, you can easily dismantle and pull them out from the screw case just after removing the screws without dismantling the screw case.***

The rotating part of the sealing ring can be easily removed from the rotor by hand.



Pull out the seal ring from the screw and replace by the new one.



## SCREW CASE ASSEMBLY

Before installing the screw case onto the gearbox, make sure to clean the surface of the screw case and the gearbox.

Assembly is done in the reverse way from the disassembly.

Carefully slide the pump housing over the stud bolts to match the gearbox.



Fig. 10

Tighten the bolts between the screw case and the gearbox using the torque from the table below.

Series	ZS100	ZS200	ZS300
Bolt size	M8	M10	M14
Torque value for bolt (Nm)	46	91	180



Fig. 11

Place both static sealing rings in the pump housing, making sure that the slot of the sealing rings matches the pin of the sealing body in the pump housing.



Fig. 12

Mount the O-ring on the sealing ring and slide it onto the rotor. Make sure that the adjustment pin fits into the slot of the slip ring.



Fig. 13

When mounting the rotors, make sure that the keys in the rotors are aligned with the splines in the shafts. Slide and insert carefully the twin screws to the screw case and treat carefully the screws to avoid damage.



Fig. 14

Fasten the screw bolts and spring washers with reference of the below torque set value using a wrench spanner.

Series	ZS100	ZS200	ZS300
Bolt size	M8	M14	M18
Torque value for Screw bolt (Nm)	22	40	53



Fig. 15

Tighten the four cap nuts to the torque shown below, so that the cover and the pump housing are tight.

Series	ZS100	ZS200	ZS300
Nut size	M8	M10	M14
Torque value for Cap nut (Nm)	14	17	30



Fig. 16

# SCREW ROTOR CLEARANCE

The screw rotor clearance must be precisely maintained to provide maximum pumping efficiency and to prevent contact between the screw rotors, screw case, and front cover during operation. If the pumping efficiency is lower than expected or if parts contact has occurred during operation (Within rated differential pressure), check the screw rotor clearances and adjust, if incorrect.

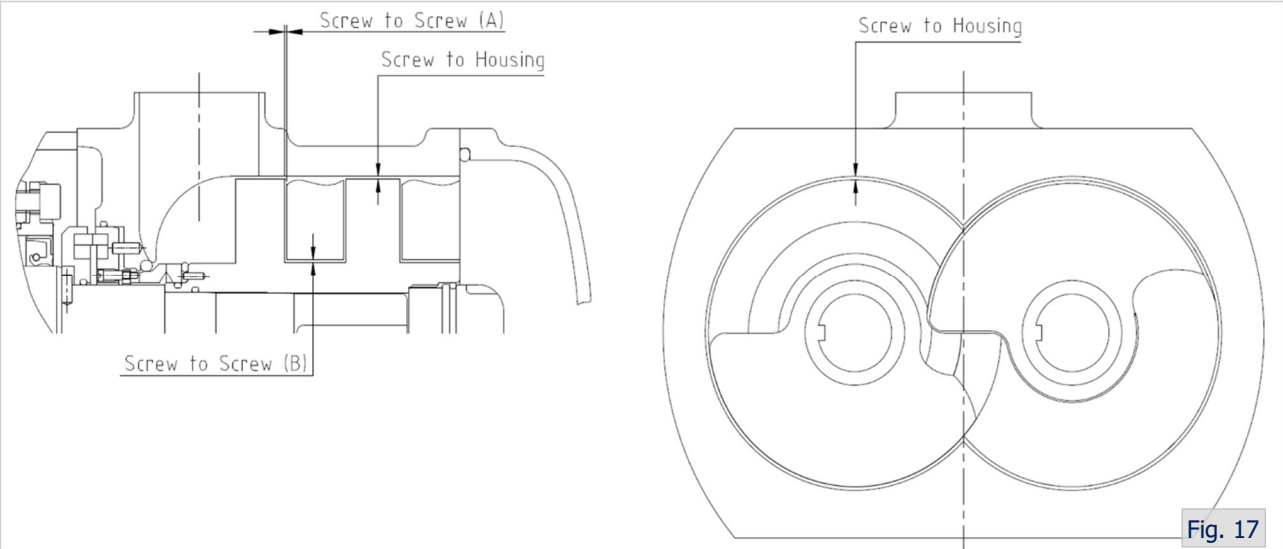

Model	Clearances for Standard (mm)			Clearances for High Temperature (mm)		
	Screw to Screw (A)	Screw to Screw (B)	Screw to Housing	Screw to Screw (A)	Screw to Screw (B)	Screw to Housing
ZS100 SERIES	0.10 ~ 0.19	0.12 ~ 0.18	0.16 ~ 0.26	0.14 ~ 0.23	0.19 ~ 0.26	0.18 ~ 0.28
ZS200 SERIES	0.12 ~ 0.21	0.14 ~ 0.20	0.20 ~ 0.30	0.16 ~ 0.25	0.24 ~ 0.30	0.22 ~ 0.32
ZS300 SERIES	0.15 ~ 0.24	0.17 ~ 0.23	0.25 ~ 0.35	0.19 ~ 0.28	0.30 ~ 0.36	0.28 ~ 0.38

## GEARBOX MAINTENANCE

### Gearbox Disassembly

Remove the drain plug and drain the oil.

Remove the shaft key (7) on the drive shaft and gearbox cover bolts (6) from the rear cover (4).

Pull the cover off the drive shaft extension. If the cover is stuck, use a soft mallet carefully to loosen it. Heavy hitting by mallet may cause damage to the cover and dowel (15).

Remove the rear cover oil seal (11) from the rear cover if the oil seal is needed to be replaced. Remove the paper gasket from the cover or gearbox.



Fig. 18

To remove the timing gears (14, 14-1) for the drive & idle shaft and power lock (181), straighten the locking tab of the bearing lock washer at the drive shaft.

Remove the lock nut (12-1) and lock nut washer (12) from the drive shaft (8).



Fig. 19

Release the setting wrench bolt and fasten the jack bolts at power lock (181) to remove power lock and pull out the gear on the idle shaft (9).

See the detailed instruction of removal power lock further in this manual.



Fig. 20



## Gearbox Assembly

1. Clean and lubricate the front & rear bearing areas of the drive & idle shafts with oil.

Fit the front bearing, spacer and rear bearing on the shaft sequentially by arbor press (or heat 120°C(250F) up by heater).

Position the gearbox (1) with wet end side facing up and be sure to support the gasket face (downside) carefully in order not to damage it.

Clean and lubricate the front and rear bearing areas with oil.

Insert the shaft perpendicularly one by one to the gearbox properly. There should be a tight sliding fit between the gearbox and the bearing outer rings. Press the shaft into the gear case until bearings are fully seated.

2. Lubricate the oil seals (21) with some oil and push them into the front seal holders (24).

3.

Place the o-ring (21) on the seal retainers (24) and slide them over the shafts. Make sure that the oil seal spring remains in place during installation. Set the Bolt & washer and tighten.

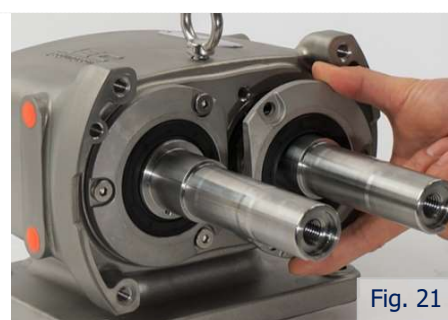

Fig. 21

4. Place the gear spacer (5mm) and insert the gear key on the slots of the drive shaft.

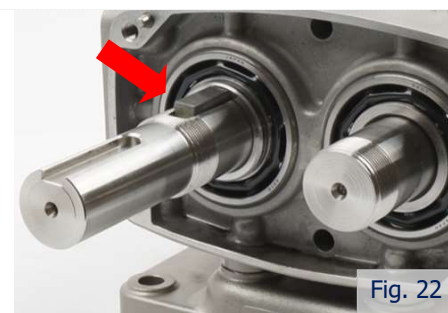

Fig. 22

5. Place the gear (14), lock washer (12) and lock nut (12-1) sequentially onto the drive shaft and tighten.

Bend one lip of the retaining ring into a slot in the retaining ring.



Fig. 23

6. Slide the second helical gear and power lock on the idle shaft. Put the wedge between the timing gears.



Fig. 24

7. On the opposite side of the shafts, interdigitate carefully both screws together and check the key fits in the groove in the shaft. Slide the screws on the shaft until they rest against the shaft shoulder.

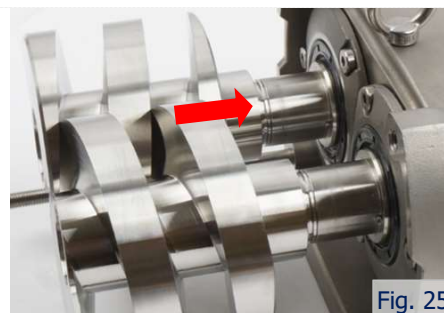

Fig. 25

8. Fasten both screw bolts and insert the 'Feeler gauge' with reference of below value to each series to secure screw timing.

Series	ZS100	ZS200	ZS300
Set Filler gauge value (mm)	0.10	0.12	0.15



Fig. 26

9. After putting feeler gauges between the flanks of the rotors, fasten the wrench bolts of the power lock (181) sequentially with below torque value.

Series	ZS100	ZS200	ZS300
Bolt size	M6	M6	M8
Torque value for bolt (Nm)	16.7	16.7	40.2



Fig. 27

See also in detail the installation manual of the power lock further in this manual.

10. Place the paper gasket (26) on the gasket face of the gearbox and mount the rear cover over the drive shaft extension onto the gearbox.

11. Set the cover bolts, drain plug and fill the gearbox with oil.

The detail instructions of the lubrications are mentioned further in this manual.



Fig. 28

## INTEGRAL TYPE UNIT ASSEMBLY

If ZS series are ordered by 'Integral type unit', they will be provided with the pump head with integral adaptor, common base with adjustable leg, motor, motor cover and bracket. However, the contents can be changed optionally.

Seat the assembled pump head and integral adaptor on the common base. Assemble the motor bracket on the common base.



Fig. 29

Insert and assemble the motor to the integral adaptor by aligning the motor shaft key and key way in the integral stud shaft.

Assemble the integral adaptor flange and motor by fastening the bolt and nut.

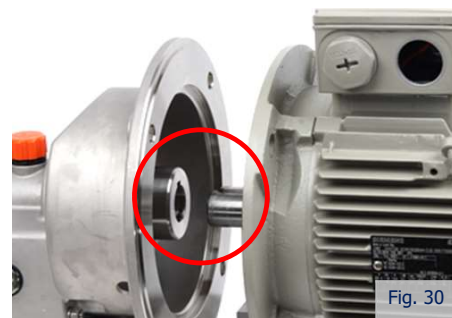

Fig. 30

Fasten the socket set screw inside of the hole by using a L-wrench.

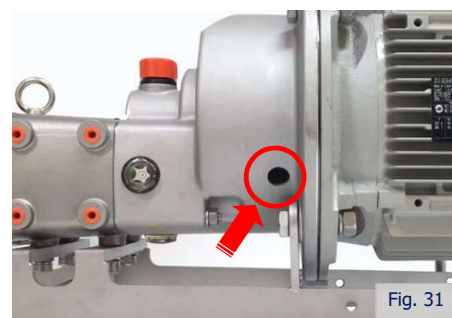

Fig. 31



## LUBRICATION

---

Pump bearings and gear should run in an oil bath. Replacement of these bearings and gear wheels is recommended after 20,000 hours of operation.

However, shorter change intervals are required for particularly difficult operating conditions, such as:

- High temperature variations
- High pressure fluctuations

The oil in the gearbox is recommended to be changed once a year or every 2,000 operating hours. However, the interval of changing oil should be adjusted according to the operating conditions.

Check the oil level in the gearbox weekly and top up the gear oil if necessary.

Filling quantities each series are shown as follows.

Series	ZS100	ZS200	ZS300
Q'ty(liter)	0.34	0.95	2.3

We recommend 'Shell Omala S4 GX150 or equivalent Synthetic gear oils' with below Qualifications/Specifications.

- Approved by Siemens MD for Flender gear units and gear motors T7300
- David Brown S1.53.106 except ISO 1000
- Approved for wind turbine gearboxes by: Gamesa, Dongfang Wind Turbines, Dalian Heavy Industries and Ninovel
- ISO 12925-1 Type CKD, except ISO 1000
- ANSI/AGMA 9005-E02 (EP), except ISO 1000
- US Steel 224, except ISO 1000
- DIN 51517-3 (CLP, except ISO 1000)

### Food Grade Gear Oil

We recommend 'NEVASTANE XSH (150 to 460) or equivalent Synthetic (PAO) gear oils' suitable for incidental food contact with below Qualifications/Specifications.

- The formulation of oils complies with the FDA chapter 21 CFR, 178.3570.
- NSF H1 registered (No 147305, No 147302, No 147303, No 147304)
- Kosher, Halal and ISO 21469 certified.
- International specification: ISO 12925-1 CKD.
- DIN 51517-3 CLP
- DIN 51354-2 - FZG A/8, 3/90°C - Fail stage > 12
- ASTM D 4172 - 4 ball test - wear (scar diameter) - 0.3 mm.

# TECHNICAL INFORMATION

---

## TECHNICAL DATA

---

- Maximum outlet pressure:

Pump series	Max outlet pressure (bar)
109	12
113	8
223	12
232	8
355	12
383	8

- Temperature Range: depending on temperature class of the rotors: max 120°C or max 150°C, see nameplate. **For ATEX pumps, the maximum temperature of the pumped liquid is 108°C.**
- Viscosity Range: max 1.000.000 cPs

## FLUSHED SHAFT SEALS

Maximum Flushing Water Pressure ..... Maximum 0.5 bar (7 psi)  
 Flushing Water Consumption ..... 0.25~0.5 l/min (30~60 cubic inches/min)



All orders for repair parts must contain the following;

1. Complete model number (located on the nameplate).
2. Pump serial number (located on the nameplate).
3. Description and position number from the parts list.

**SINGLE MECHANICAL SEAL & TRIPLE LIP SEAL**

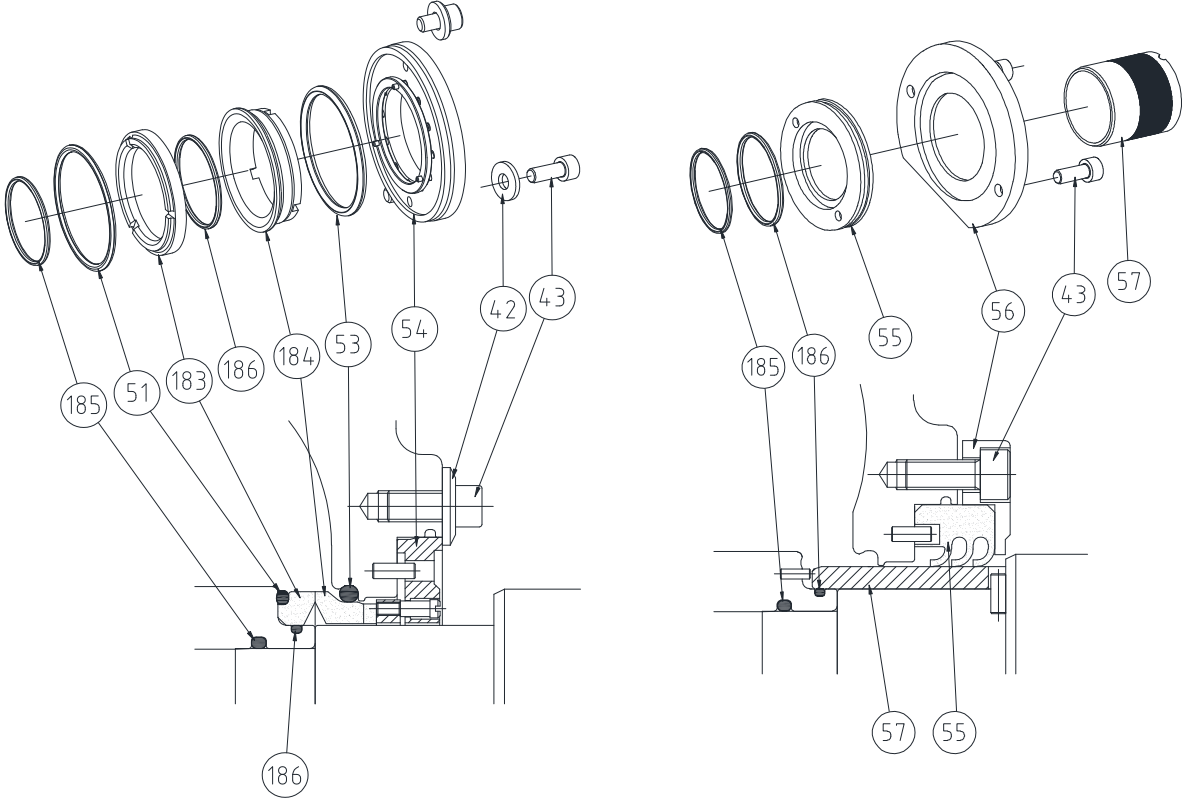

Single Mech. Seal

Triple Lip Seal

**DOUBLE MECHANICAL SEAL**

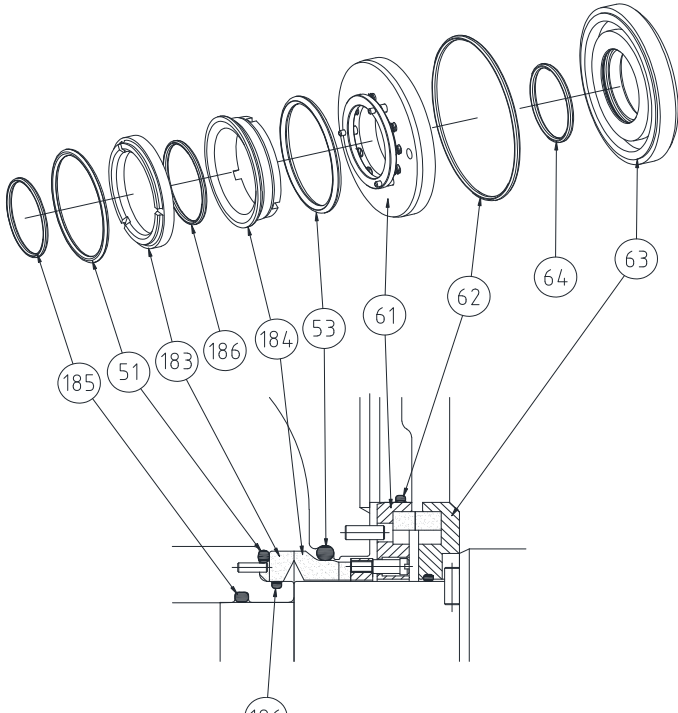

## O-RING SEAL & DOUBLE O-RING SEAL

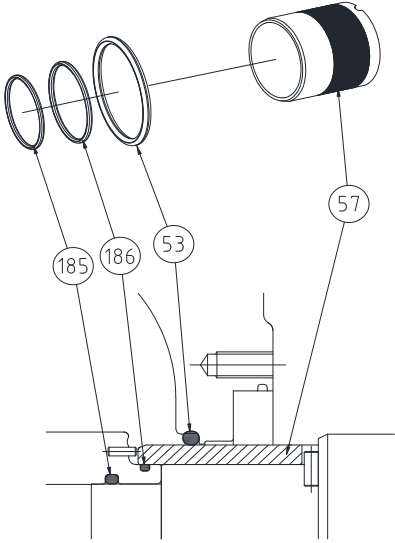

O-ring Seal

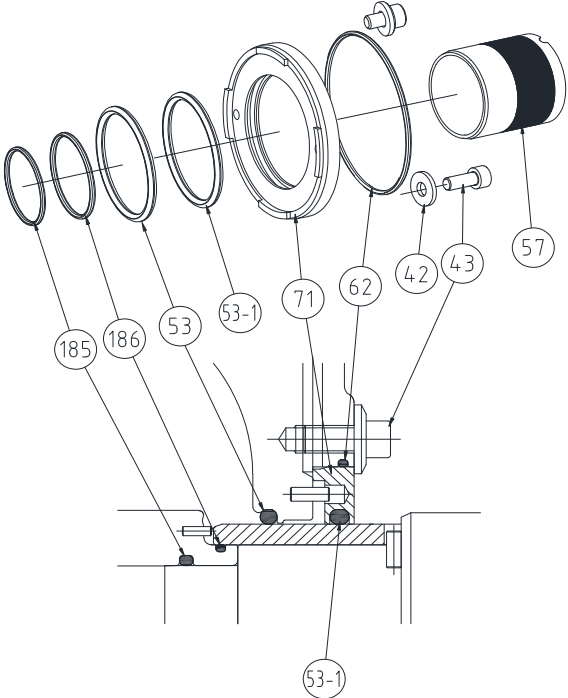

Double O-ring Seal

## FLUSHED MECHANICAL SEAL

